

TECHNICAL DATASHEET



EF REDUCED TEE 90°

04 Update - 03/2023

TECHNICAL DATA

Article No	001 117 2042 0163
d1 (mm)	160
d2 (mm)	110
D (mm)	204
Z (mm)	320
L (mm)	191
le1 (mm)	86
le2 (mm)	87
m (mm)	41,2
Weight (Kg)	3,712
Box Quantity (pcs)	3
Box Dimension (cm)	55x40x36

INJECTION MOULDED

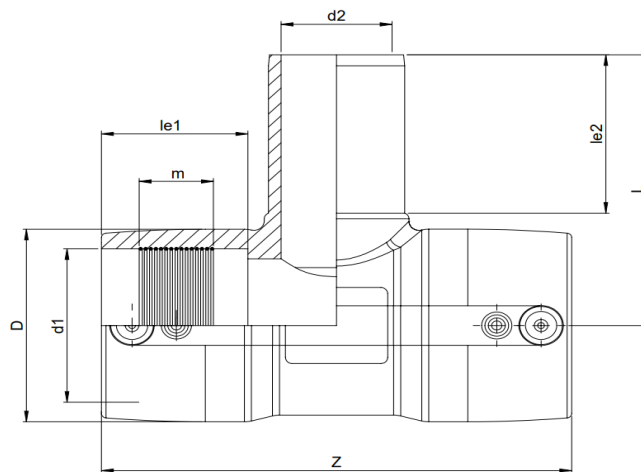

IDENTIFICATION OF PRODUCT

D(mm)	160-110
SDR	11
RAW MATERIAL	PE 100
PRESSURE CLASS	16 Bar Water 10 Bar Gas
TRADEMARK	NTG
EXECUTION	Injection Moulded
STANDARD	EN 12201-3 EN 1555-3 AS / NZS 4129
SPECIFICATION	Suitable for SDR9...17 pipe 4 mm pin connectors

EF SPECIFICATION

WELDING VOLTAGE	40V
RESISTANCE	0,91 Ω
WELDING TIME	360 Sec.
COOLING TIME	20 Min.
WINDING TYPE	Monofilar
WELDING BARCODE	



971420331603400916360110

Tolerance on diameters and thickness according to the standards. The other dimensions are specialized. Tolerance $\pm 5\%$. NTG PLASTIK reserves all the right to change any information without giving prior notice. The production, distribution and utilization of this document without explicit authorization is prohibited.